



Fieldbus International AS

ENOTEC



Process- And Environmental Measurement GmbH

Page

1

OXITEC5000 & COMTEC 6000

FF interface

Specification for FintFF T611

by Jørgen Norendal

Document no:	R1031_04_01
Version no:	1.3
Release date:	14.10.04



Fieldbus International AS

ENOTEC



Process- And Environmental Measurement GmbH

Doc. title: OXYTEC5000 FintFF specification	Ver.no: 1.3
Doc. no.: R1031_04_01	

Document type: Specification	Document description: FF specification
---------------------------------	---

Summary:

This is the specification of the FintFF index structure.

The device supports two Function Blocks (two dynamic variables) that is used for the process control system.

There are two systems which may be controlled via the FF interface.
 The OXITEC 5000 (supports Oxygen measurements)
 The COMTEC 6000 (supports Oxygen and COe measurements)

Important note:
The meaning of "CO" in this document is always "combustibles", not carbon monoxide only!

There will be one module that will support both an OXYTEC and a COMTEC application.
 The DD (device driver will be made dynamic in such a way that the COMTEC related parameters are not available unless it is an COMTEC application).

In order to differentiate between the OXITEC and the COMTEC application the FF module will read a parameter from the instrument that contains an enumeration that makes the differentiation between the two types.

Version	Revision	Reason for issue	Date	Issuer	Checked	Des.check	Approved
0	1	First issue	13.09	Joen			
0	2		10.05	Hla			
0	9		07.06	Hla			
1	0	Final issue from specification phase	15.06	Hla			
1	1	Corrections	30.08	Hla			
1	2		08.09	Mbu			
1	3	Status coding DS65/New indexes	14.19	Hla			

Issuer: Jørgen Norendal	Checked by:	Design checked by:	Approved by:
----------------------------	-------------	--------------------	--------------



Fieldbus International AS

ENOTEC



Process- And Environmental Measurement GmbH

TABLE OF CONTENTS

1.	DEVICE MODEL	3
2.	RESOURCE BLOCK	5
3.	TRANSDUCER BLOCK	8
4.	ANALOG INPUT FB	11
5.	MECHANICAL.....	18
6.	ELECTRICAL CONNECTIONS (SOLDERING HOLES).....	19

1. DEVICE MODEL

The FintFF module comprises a FF fieldbus protocol, a FF FB application and a serial protocol for communication with the OXITEC5000 or the COMTEC6000 .

The parameters of the instrument are mapped into the TransducerBlock of the FF module.

The specific parameters appear as index numbers within the FF module.

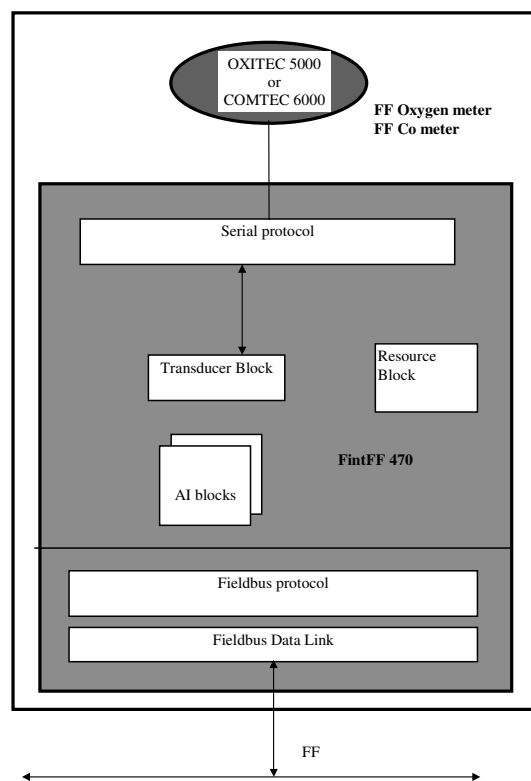

The module supports in total

- 2 AI blocks
- 1 Transducer block

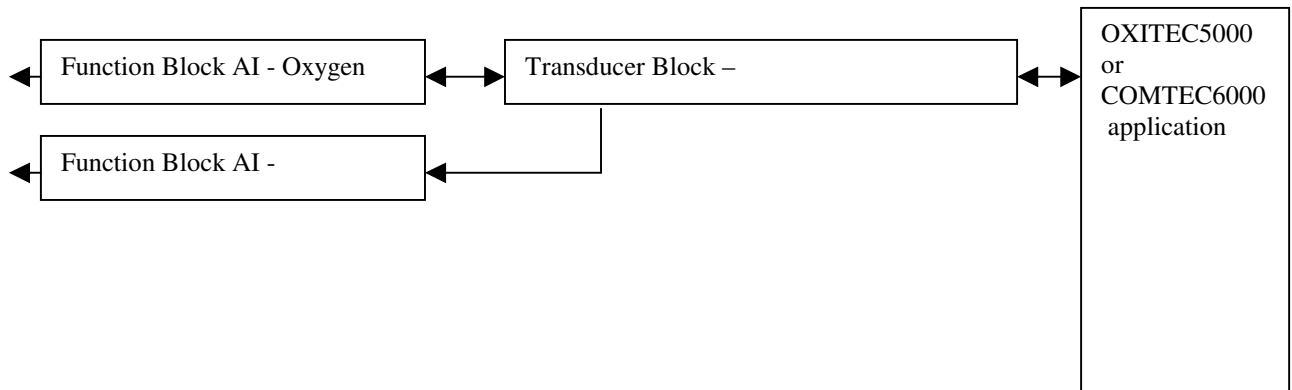

Dataflow in T611

The FintFF T611 module supports two dynamic variables. The variables are read from Instrument, temporarily stored in the Transducer Block and are processed through the Function Block before being published on the FF network.

The dynamic variables are presented as a float value with status, in total 5 bytes. The status gives the quality of the variable, whether it is “Bad”, “Uncertain” or “Good”.

The AI Function Block is a fully standardised Foundation module. It contains scaling, low-pass filtering and alarm handling.



2. RESOURCE BLOCK

The Resource Block contains all parameters that describe the physical device and the resources the device has for providing the required FF services.

The parameters given are standard parameters that shall be supported. They are not described in detail in this document. For further information see the FF specification documents.



Parameters of the Resource Block

Abs. Index	Name of variable	Data type	No of bytes	Access	Storage	Description	EEPROM	Default
1	ST_REV	Usignd16	2	r				0
2	TAG_DESC	Visible String	32	r,w	S		y	Spaces
3	STRATEGY	Usignd16	2	r,w	S		y	0
4	ALERT_KEY	Usignd8	1	r,w	S	1- 255	y	0
5	MODE_BLK	DS 69	4	mix	mix		y	O/S
6	BLOCK_ERR	Bitstring	2	r	D	See below		
7	RS_STATE	Usignd8	1	r	D	State of the Resource (handeled by NI code)		
8	TEST_RW	DS-85	112	r,w	D	For conformance testing only		
9	DD_RESOURCE	Visible String	32	r	S	Not supported	y	null
10	MANUFAC_ID	Usignd32	4	r	S	Controlled by FF (Use FINTs number 0x00a000)	y	
11	DEV_TYPE	Usignd16	2	r	S	0001 – Two FBs	y	
12	DEV_REV	Usignd8	1	r	S	Set by mfr = 01	y	
13	DD_REV	Usignd8	1	r	S	Set by mfr = 01	y	
14	GRANT_DENY	DS-70	2	r,w	D	User controlled		
15	HARD_TYPES	Bitsring	2	r	S	0x0001 – Scalar Input	y	
16	RESTART	Usignd8	1	r,w	D	1 = run, 2 = restart resource, 3 = Restart with Default processor 4 = Restart processor 5 = factory defaults		
17	FEATURES	Bitstring	2	r	S	See below	y	
18	FEATURES_SEL	Bitstring	2	r,w	S	See below	y	Set by mfr
19	CYCLE_TYPE	Bitstring	2	r	S	See below	y	
20	CYCLE_TYPE_SEL	Bitstring	2	r,w	S	See below	y	0
21	MIN_CYCLE_T	Usignd32	4	r	S	400 ms	y	
22	MEMORY_SIZE		14	r	D	TBD		
23	NV_CYCLE_TIME		13			TBD	y	0
24	FREE_SPACE					TBD		
25	FREE_TIME					TBD		
26	SHED_RCAS	Usignd32	4	r,w	S	TBD	y	64000
27	SHED_ROUT	Usignd32	4	r,w	S	TBD	y	64000
28	FAULT_STATE					TBD		
29	SET_FSTATE					TBD		
30	CLR_FSTATE					TBD		
31	MAX_NOTIFY	Usignd8	1	r	S	20	Y	
32	LIM_NOTIFY	Usignd8	1	r,w	S	20 = alarms not reported	y	1
33	CONFIRM_TIME	Usignd32	4	r,w	S	64000	y	64000
34	WRITE_LOCK	Usignd8	1	r,w	S	1 = Unlocked , 2 = Locked	Y	1
35	UPDATE_EVT	DS-73	14	r	D			
36	BLOCK_ALM	DS72	13	r	D			
37	ALARM_SUM	DS-74	8		mix			
38	ACK_OPTION	Bitstring	2	r,w	S	0 –AutoAckdisabled 1- AutoAck enabled	Y	0
39	WRITE_PRI	Usignd8	1	r,w	S	0-15	Y	0
40	WRITE_ALM	DS-72	13	r	D	supported		
41	ITK_VER	Usignd16	2	r	S	Set by FF- test revision	Y	
42	SW_Revision	ASCII	12	r		Firmware revision of SW and HW.		

Features and Featured_Sel

¹Resource is the same as the processor



Fieldbus International AS

ENOTEC



Process- And Environmental Measurement GmbH

Bit		Coding	Supported	Comment
0	Unicode string	0	No	
1	Reports supported	1	Yes	
2	Fault State supported	1	Yes	
3	Soft Write Lock Supported	1	Yes	
4	Hard Write Lock supported	0	No	
5	Output Readback supported	1	Yes	
6	Direct write to output hardware	0	No	
7	Change of BYPASS in automatic mode	0	No	

Cycle_type and Cycle_type_Sel

Bit		Coding	Supported	Comment
0	Scheduled	1	Yes	
1	Completion of block execution	0	No	
2	Manufacturer specific	0	No	

Storage

The storage type can either be S,D or N. S and N means that the parameters are stored in non-volatile memory. The parameters of the type S is under Static Revision control. Each time a parameter of the type S is changed, the static revision parameter ST_REV is incremented. This mechanism is used to keep track of the changes of set-up parameters in the device. Variables of the type D (dynamic) are only stored in RAM.



3. TRANSDUCER BLOCK

This TransducerBlock is the image of the OXITEC/COMTEC device on the FF bus. It contains a standard part and all OXITEC/COMTEC specific parameters.

Parameters of the Transducer Block

Abs. Index	Name of variable	Data type	No of bytes	Access	Storage	Description	EE-PROM	Default
1	ST_REV	Unsigned16	2	r				0
2	TAG_DESC	Visible String	32	r,w	S		y	Spaces
3	STRATEGY	Unsigned16	2	r,w	S		y	0
4	ALERT_KEY	Unsigned8	1	r,w	S	1- 255	y	0
5	MODE_BLK	DS 69	4	mix	mix		y	O/S
6	BLOCK_ERR	Bitstring	2	r	D	See below		
7	UPDATE_EVT	DS 73	5	r	D			
8	BLOCK_ALM	DS 72	5	r	D		y	
9	TRANSDUCER_DIRECTORY	Unsigned16	2	r		One element		1
10	TRANSDUCER_TYPE	Unsigned16	2	r		Other = 65535	y	65535
11	XD_ERROR	Unsigned8	1	r	D		y	0
12	COLLECTION_DIRECTORY	Unsigned32	4	r	D	One element		1
13	OXYGEN	DS 65	5	r	D	PV		
14	O2_CELL_VOLTAGE	Float	4	r	D			
15	O2_CELL_TEMPERATURE	Float	4	r	D			
16	O2_CURRENT_OUT	Float	4	r	D	Dynamic variable		
17	STATUS_SIGNALS	Unsigned32	4	r	D	Instrument status		
18	O2_CALIBRATION_STATUS	Unsigned16	2	r	D	Calibration status		
19	O2_CONSTANT	Float	4	r,w	S			
20	O2_SLOPE	Float	4	r,w	S			
21	O2_LIMIT_1	Float	4	r,w	S			
22	O2_LIMIT_1_FUNCTION	Unsigned32	4	r,w	S			
23	O2_LIMIT_2	Float	4	r,w	S			
24	O2_LIMIT_2_FUNCTION	Unsigned32	4	r,w	S			
25	UPPER_RANGE	Float	4	r,w	S	Not in use		
26	LOWER_RANGE	Float	4	r,w	S	Not in use		
27	O2_SINGLE_POINT_CALIB	Unsigned8	1	r,w	D	Execute calibration on write 1		
28	O2_TWO_POINT_CALIB	Unsigned8	1	r,w	D	Execute calibration on write1		
29	COM_STATUS	Unsigned8	1	r	D			
30	CO	DS 65	5	r	D	Carbon monoxid		
31	CO resistance	Float	4	r	D	CO Sensor Resistance		
32	CO sens. Temperature	Float	4	r	D	CO Sensor Temperature		
33	CO heater resistance	Float	4	r	D	CO Heater resistance		
34	CO CURRENT_OUT	Float	4	r	D			
35	CO Calibration zero offset	Float	4	rw	S			
36	CO Calibration span offset	Float	4	rw	S			
37	CO Measuring range	Float	4	rw	S			
38	CO_CALIBRATION_STATUS	Unsigned16	2	r	D			
39	CO_SINGLE_POINT_CALIB	Unsigned8	1	r,w	D			
40	CO_TWO_POINT_CALIB	Unsigned8	1	r,w	D			
41	DEVICE_TYPE	Unsigned8	1	r				



Relative Index	Variable Name	Storage/Value/ register	Comment
1	ST_REV	EEPROM	
2	TAG_DESC	EEPROM	
3	STRATEGY	EEPROM	
4	ALERT_KEY	EEPROM	
5	MODE_BLK	Target mode to EEPROM	
6	BLOCK_ERR	RAM	
7	UPDATE_EVT	RAM	
8	BLOCK_ALM	Disabled to EEPROM	
9	TRANSDUCER_DIRECTORY	Fixed/ 1,10	1,10
10	TRANSDUCER_TYPE	Fixed / 0xff ff	Other
11	XD_ERROR	RAM	See table
12	COLLECTION_DIRECTORY	Fixed	1, 13
13	OXYGEN	RAM//00	
14	CELL_VOLTAGE	RAM//01	
15	CELL_TEMPERATURE	RAM//02	
16	CURRENT_OUT	RAM//03	
17	STATUS SIGNALS	RAM //04	
18	CALIBRATION_STATUS	RAM // 05	0 – last Calibration successfully finished; 1 – last Calibration fault; 2 – Calibration still active 255 – Not Initialised
19	CONSTANT	OXY //10	
20	SLOPE	OXY // 11	
21	LIMIT_1	OXY // 12	
22	LIMIT_1_FUNCTION	OXY // 13	Min = 0 Max = 1
23	LIMIT_2	OXY // 14	
24	LIMIT_2_FUNCTION	OXY // 15	Min = 0 Max = 1
25	UPPER_RANGE	OXY // 16	NB! I am not sure this exists – comment Halvor
26	LOWER_RANGE	OXY // 17	NB! I am not sure this exists – comment Halvor
27	SINGLE_POINT_CALIB	OXY // 20	
28	TWO_POINT_CALIB	OXY // 21	
29	COM_STATUS	RAM	Internal communication status 0 = OK 1 = Fatal error 255 – Not Initialised
30	CO	RAM//06	
31	CO resistance	RAM//07	
32	CO sens. Temperature	RAM//08	
33	CO heater resistance	RAM//09	
34	CO CURRENT_OUT	RAM//22	
35	CO Calibration zero offset	OXY//23	
36	CO Calibration span offset	OXY-//24	
37	CO Measuring range	OXY //25	
38	CO_CALIBRATION_STATUS	OXY//27	
39	CO_SINGLE_POINT_CALIB	OXY//28	
40	CO TWO_POINT_CALIB	OXY//29	
41	DEVICE_TYPE	OXY//26	



Transducerblock view objects

		View 1	View 2	View 3	View 4
1	ST_REV	2	2	2	2
2	TAG_DESC				
3	STRATEGY				2
4	ALERT_KEY				1
5	MODE_BLK	4		4	
6	BLOCK_ERR	2		2	
7	UPDATE_EVT				
8	BLOCK_ALM				
9	TRANSDUCER_DIRECTORY				
10	TRANSDUCER_TYPE	2	2	2	2
11	XD_ERROR	1		1	
12	COLLECTION_DIRECTORY				
13	OXYGEN	5		5	
14	CELL_VOLTAGE			4	
15	CELL_TEMPERATURE			4	
16	CURRENT_OUT			4	
17	STATUS_SIGNALS			4	
18	CALIBRATION_STATUS			2	
19	CONSTANT				4
20	SLOPE				4
21	LIMIT_1				4
22	LIMIT_1_FUNCTION				4
23	LIMIT_2				4
24	LIMIT_2_FUNCTION				4
25	UPPER_RANGE				4
26	LOWER_RANGE				4
29	COM_STATUS			1	
30	CO	5		5	
31	CO resistance			4	
32	CO sens. Temperature			4	
33	CO heater resistance			4	
34	CO CURRENT_OUT			4	
35	CO Calibration zero offset				4
36	CO Calibration span offset				4
37	CO Measuring range				4
	Total	21	4	51	51

XD_ERROR

Value	Error	Usage
20	Electronics failure	Any failure on OXITEC
22	I/O failure	No internal serial communication



4. ANALOG INPUT FB

The AI Function Block is a fully standardised module containing scaling, low-pass filtering and alarm handling. Some functions are duplicated compared to the instrument itself. This is the nature of these blocks and will have to be so. The Function Blocks are application modules that are connected together across a fieldbus network. They are fully under the control of the configuration tool. For further understanding of the Function block application, read the AI Function Block datasheet.

Parameters of the AI Function Block

Abs. Index	Name of variable	Data type	No of bytes	Access	Storage	Description	EEPROM	Default
1	ST_REV	Usignd16	2	r				0
2	TAG_DESC	Visible String	32	r,w	S		y	Spaces
3	STRATEGY	Usignd16	2	r,w	S		y	0
4	ALERT_KEY	Usignd8	1	r,w	S	1- 255	y	0
5	MODE_BLK	DS 69	4	mix	mix		y	O/S
6	BLOCK_ERR	Bitstring	2	r	D	See below		
7	PV	DS 65	5	r	D			
8	OUT	DS 65	5	r	N		y	
9	SIMULATE	DS 82	11	r,w	D	Includes also input from the TransducerBlock		disabled
10	XD_SCALE	DS 68	11	r,w	S		y	0-100%
11	OUT_SCALE	DS 68	11	r,w	S		y	0-100%
12	GRANT_DENY	DS 70	2	r,w	D	For use by supervisory systems		
13	IO_OPTS	Bitstring	2	r,w	S	Low – cut off enable	y	0
14	STATUS_OPTS	Bitstring	2	r,w	S	Affects statushandling	y	0
15	CHANNEL	usignd16	2	r,w	S	Channel 1 = 1 (only choice)		0
16	L_TYPE	Unsigned8	1	r,w	S	1- Direct (only choice)	y	0
17	LOW_CUT	Float	4	r,w	S		y	0
18	PV_FTIME	float		r,w	S			0
19	FIELD_VAL	DS 65	5	r	D			0
20	UPDATE_EVT	DS 73	14	r	D	Static revision update event		
21	BLOCK_ALM	DS 72	13				y	0
22	ALARM_SUM	DS -74	mix					
23	ACK_OPTION	Bitstring	2	r,w	S	0-AutoAck Disabled / 1 – AutoAck enabled		0
24	ALARM_HYS	float	4	r,w	S	0-50% valid range	y	0.5%
25	HI_HI_PRI	Unsigned8	1	r,w	S	0-15	y	0
26	HI_HI_LIM	float	4	r,w	S	OUT_SCALE units	y	+INF
27	HI_PRI	Unsigned8	1	r,w	S	0-15	y	0
28	HI_LIM	float	4	r,w	S	OUT_SCALE units	y	+INF
29	LO_PRI	Unsigned8	1	r,w	S	0-15	y	0
30	LO_LIM	float	4	r,w	S	OUT_SCALE units	y	-INF
31	LO_LO_PRI	Unsigned8	1	r,w	S	0-15	y	0
32	LO_LO_LIM	float	4	r,w	S	OUT_SCALE units	y	-INF
33	HI_HI_ALM	DS 71	16	r	D			
34	HI_ALM	DS 71	16	r	D			
35	LO_ALM	DS 71	16	r	D			
36	LO_LO_ALM	DS 71	16	r	D			



Block Error

Bit	Bit name	Usage
0	Other (LSB)	Not supported
1	Block configuration error	supported
2	Link configuration error	Not supported
3	Simulate active	Supported
4	Local Override	Not used
5	Device fault state set	Not supported
6	Device needs maintenance soon	Not used
7	Input failure/Process variable status BAD	Not used
8	Output failure	Not supported
9	Memory failure	Not supported
10	Lost static data	Not supported
11	Lost NV data	Not supported
12	Readback Check failed	Not used
13	Device needs maintenance now	Not Supported
14	Power-up	Not Supported
15	Out of service (MSB)	Supported

IO_OPTS		
Bit	Parameter	Supported
0 - 9	Not used	No
10	Low cutoff	Enables cut-off function
11 - 15	Reserved	

STATUS_OPTS		
Bit	Parameter	Supported
0-2	Not used	No
3	Propagate Fault Forward	Yes
4-5	Not used	No
6	Uncertain if Limited	Yes
7	BAD if Limited	Yes
8	Uncertain if MAN mode	Yes
9	Not used	No
10-15	Reserved	

ALARM_SUM and ACK_OPTION

Bit	Bit name	Supported
0	Discrete alarm	Not used
1	Hi-Hi alarm	Yes
2	Hi alarm	Yes
3	Lo-Lo alarm	Yes
4	Lo alarm	yes
5	Deviation Hi alarm	Not used
6	Deviation Lo alarm	Not used
7	Block alarm	yes



Internal communication

The communication between T611 and the OXITEC 5000 / COMTEC 6000 is based on request from T611 and responses from the OXITEC 5000 / COMTEC 6000 in a Master Slave communication. The protocol is defined in "Specification Serial Protocol COMTEC6000 to HART module". ("Specification Serial Protocol OXITEC 5000 to HART module")

Dynamic variables.

The T611 is continuously reading the dynamic variables from OXITEC using the serial communication line. Each 5 sec. it reads all the variables and updates the dynamic variables in the Transducer Block.

In case of a communication error between the OXITEC / COMTEC and T611, a reading may be lost. This simply implies that the measured variable is not updated. The status of the dynamic variable indicate that measurements are lost. If there is a permanent loss of communication defined as no update for 15 sec (3 readings from device), This is flagged in the status of the dynamic variables.

DS – 65 Value&Status:

status
float

DS-65 status byte and the conditions for status byte settings:

MSB		Substatus					LSB	FOUNDATION meaning	Oxitec use
0	0	0	0	1	0			not connected	a)
0	0	0	0	1	1	X	x	device failure	b)
0	0	0	1	0	0	1	1	sensor failure	c)
0	0	0	1	1	1	1	1	out of service	d)
0	1	0	0	0	1	1	1	Uncertain – Last usable Value	e)
0	1	0	1	0	0	x	x	Uncertain – sensor conversion not accurate	f)
1	0	0	0	0	0	x	x	Good - Non cascade	measured value OK

- There is no internal communication
- Resource block is "Not OK" due to FF or OXITEC / COMTEC module failure
- No sensor value- hardware failures reported from OXITEC / COMTEC, see below
- AI Function Block in O/S mode or in calibration or initialisation
- No update from sensor, missed one reading
- Based on status from OXITEX / COMTEC, see below



Read Status

When the user wants to read status, he reads STATUS in the Transducer Block The reading from this register would normally be maximum 5 sec. old. Worst case is 15 sec in the case of lost communication. If the communication still fails this will be flagged in the COM_STATUS parameter.

Each time the STATUS is read, it is evaluated to see if the DS-65 status should be affected.

When some of the OXITEC 5000 / COMTEC 6000 Status signals (Code 04) are set, the XD_ERROR flag in the TransducerBlock is set signaling that there is a problem with the instrument.

The STATUS is used to code the status of the dynamic variables (DS-65) in the Transducer Block.

Coding of STATUS :

Bit-enumerated

		Transducer Block XD error	DS 65 status CO	DS 65 status oxygen
Bit 0	CONSTANT out of tolerance			No consequence
Bit 1	SLOPE out of tolerance			No consequence
Bit 2	Ref.gas flow to low	y		Uncertain-Sensor conversion not accurate
Bit 3	Cal.gas flow to low	y		Uncertain-Sensor conversion not accurate
Bit 4	Heating system don't work	y		BAD Device failure
Bit 5	Wire breakage thermoelement	y		BAD Device failure
Bit 6	Error cell signal out of range	y		Uncertain-Sensor conversion not accurate
Bit 7	Error probe heater	y		BAD Sensor failure
Bit 8	Temp. of electronic out of spec.	y		Uncertain-Sensor conversion not accurate
Bit 9	Probe temperature to high	y		Uncertain-Sensor conversion not accurate
Bit 10	Probe temperature to low	y		Uncertain-Sensor conversion not accurate
Bit 11	Alarm limit1			No consequence
Bit 12	Alarm limit2			No consequence
Bit 13	Data fault EEPROM	y		BAD Device failure
Bit 14	Measuring value memory active			
Bit 15	Error by trying ACAL also occurs if any error by calibration over FF	y		Uncertain-Sensor conversion not accurate
Bit 16	Not used			
Bit 17	CO calibration margin to low	y	Uncertain-Sensor conversion not	



Fieldbus International AS

ENOTEC



Process- And Environmental Measurement GmbH

			accurate	
Bit 18	Wire breakage CO sensor	y	BAD Sensor failure	
Bit 19	Error Heater CO sensor	y	BAD Sensor failure	
Bit 30	Instrument in initialising		BAD Out of Service	BAD Out of Service
Bit 31	Calibration Busy		BAD Out of service	BAD Out of service

Bit-enumerated coding of COM_STATUS

		Transducer Block XD error
Bit 0	Permanent internal communication failure	y

The T611 module has lost communication with OXITEC.

Calibrate

The Calibration is started by writing to the TranducerBlock index. The FF write requires an immediate response and will not wait for the calibration to complete. A positive response will be given if the OXITEC 5000 / COMTEC 6000 accepts the command. This is a verification that the calibration has started. In order to see if the calibration is successful or not, the Master must read the calibration status. This procedure will be used both for single point and two-point calibration.

Power-up

The OXITEC / COMTEC system has a power up time. This time depends on the installation of the probe of the type of probe and the environment. The instrument will set a status flag for heating up (power up) phase. This is flagged in bit 30 of the Status. In this period the status of the dynamic variables are coded "BAD- Out of service". This is done in the Transducer Block.

At power-up T611 will read the instrument type from the instrument, by reading Code 26 Device Type-

Device type coding:

- 0 = OXITEC
- 1 = COMTEC



Communication

The T611 protocol machine controls the communicating with the OXITEC 5000 / COMTEC 6000. This protocol machine has the following functions:

- Generation of OXITEC 5000 / COMTEC 6000 frames
- Observing OXITEC 5000 / COMTEC 6000 time-out
- Conversion of data (i.e.)
 - ASCII – float
 - ASCII – Unsigned 32
- Conversion of dimension into Unit code
 - Table with the required unit codes
- Conversion of code
 - ASCII - unsigned 8
- Arbitration of traffic.

The data elements in the OXITEC data frame are converted in the protocol machine. This is done to make the data types FF compatible. On FF the following data types are used, DS-65, FF unit codes etc.

Arbitration of traffic.

Reading of dynamic variables is done on a fixed schedule, once every 5 sec. A request for a set-up parameter or an execute command may appear at any time and is executed immediately if no traffic with the OXITEC / COMTEC is pending. If scheduled traffic is about to start, the scheduled traffic (reading of dynamic variables) will wait.

Device Restart

This command acts on the FF module only.

5. MECHANICAL

The board layout is shown below.

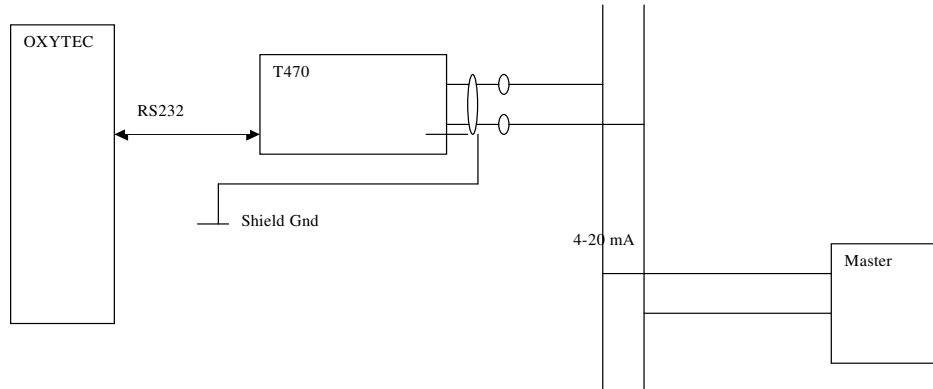

The figure above shows the Wiring connection between OXITEC 5000 / COMTEC 6000 and T611

6. ELECTRICAL CONNECTIONS (SOLDERING HOLES)

Connection	Pin No.	Signal Type	Description
FF+	3	Line connection	Connection for the FF bus interface
FF-	2	Line connection	Connection for the FF bus interface
EMC GND	1		Termination of shield - optional

Table 1 Bus T611 connections – J4

The loop connection may optionally be supplied by a screw terminal. The input is polarity insensitive.

The power connection may optionally be supplied by a screw terminal

Connection	Pin No.	Signal Type	Description
	1		NC

Table 2 Sensor interface connection – J1 – digital

Connection	Pin No.	Signal Type	Description

Table 3 Sensor interface connection – J6 - digital

The configuration must be specified when ordering

Connection	Pin No.	Signal Type	Description
Tx/Data_A	1	RS232	Transmit from T611
Rx/Data_B	2	RS232	Receive to T611
GND	3		Signal ground

Table 4 Sensor interface connection – J5 – RS232 or RS485 interface

The module can be configured either for HART output or a MODbus/RS485 output. The configuration is chosen by onboard 0 ohm resistor straps.



Fieldbus International AS

ENOTEC



Process- And Environmental Measurement GmbH

Connection	Pin No.	Signal Type	Description
MOD_A	1	RS485	NC
MOD_B	2	RS485	NC
EMC Gnd	3	Protection	NC

Table 5 Sensor interface connection – J7 – External MODbus interface (RS485)