



---

# Specification for FintHRT T004 for use with OXITEC<sup>®</sup> 5000 & COMTEC<sup>®</sup> 6000 HART commands

by Halvor Landet

Document no:	R1031-05_01
Version no:	1.0
Release date:	04.01.05



Doc. title: FintHRT T004 specification Doc. no.: R1031-05_01	Ver.no: 1.0
---	-------------

Document type: <b>Specification document</b>	Document description: <b>HART command for OXITEC® 5000 &amp; COMTEC® 6000</b>
---	--

Summary:

The application of the HART Commands in FintHRT T004 for the COMTEC 6000 application is described in this document.

The mechanical dimensions and electrical connections are defined.

Generic commands that operates directly on the COMTEC instrument is defined.

The T004 modules shall support both COMTEC 6000 and OXITEC 5000. Command 26 defines whether the device is either type. The Device ID set depending on which to read.

**Important note:**  
**The meaning of “CO” in this document is always “combustibles”, not carbon monoxide only!**

Rev.	Version	Reason for issue	Date	Issuer	Checked	Approved
1	0		04.01.05			

Issuer: <b>Halvor Landet</b>	Checked by:	Approved by:
---------------------------------	-------------	--------------

**TABLE OF CONTENTS**

1. INTRODUCTION .....3  
 2. HART COMMANDS .....3  
 3. UNIVERSAL COMMANDS .....4  
 4. COMMON PRACTICE COMMANDS .....7  
 5. DEVICE SPECIFIC COMMANDS.....9  
 6. T004 DATAFLOW .....10  
 7. STATUS FLAGS.....15  
 8. MECHANICAL .....15  
 ELECTRICAL CONNECTIONS (SOLDERING HOLES).....16

**References**

- [1] Universal Command Specification, HCF\_SPEC-127, Rev: 5.2
- [2] Common Practice Command Specification, HCF\_SPEC-151, Rev.: 7.1
- [3] Common Tables, HCF\_SPEC-183, Rev.: 9.0

**Abbreviations and definitions**

DD	Device Description. Language to describe device parameters and host menus
HART	Highway Addressable Remote Transducers
HCF	HART Communication Foundation



## 1. INTRODUCTION

This document describes the HART Commands and how they shall be used in COMTEC 6000.

This document also defines the mechanical dimensions and electrical interfaces for FintHRT T004.

For all ASCII characters are HART ASCII characters are used.

## 2. HART COMMANDS

The HART commands specified are divided into three categories

- Universal Commands
- Common Practice Commands
- Device specific Commands

A generic configuration tool cannot use device Specific commands unless a Device description is developed. The device specific commands implemented in this application are some of the same as used in FintHRT T003. They are intended only for use in factory for initial set-up using a DOS program COMTEC.exe.

A configuration station can use Universal- and Common Practice commands implemented with SW packages like AMS from Fisher Rosemount and hand-held configurator such as HH275 from Fisher Rosemount.

.



### 3. UNIVERSAL COMMANDS

Mandatory commands for any HART transmitter.

Command Number and Function	Data in Command	Data in reply	Response code	Storage type	Code	Comment
0 Read unique identifier	none	Byte 0 "254" (expansion) Byte 1 Manufacturer ID Byte 2 Mfr. Device. Type Byte 3 Num. of preamble Byte 4 Universal cmd rev Byte 5 Dev. spec.cmd rev Byte 6 software revision Byte 7 hardware revision Byte 8 device fun. flag Byte 9-11 Device ID num.		Hardcoded Hardcoded EEPROM EEPROM Hardcoded Hardcoded Hardcoded EEPROM Hardcoded EEPROM		Fint = 0xa0 COMTEC 6000 = 0xeb Default 5 5 HART 5.0 1 3 Hardware rev. 3 5 bits are used (32 revisions possible). First 3 bits are physical signalling code: yyy = 000 = Bell 202 Current Multisensor device = No , EEPROM control = No -> 0 Serial number configured by Fint before shipment
1 Read PV	none	Byte 0 PV unit code Byte 1-4 PV F	8 Update failure	RAM	00	Default unit 57 = %

Command Number and Function	Data in Command	Data in reply	Response code	Storage type	Code	Comment
<b>2</b> Read Current & % of range	None	Byte 0-3 current (mA) F Byte 4-7 % of range F			03	Read from COMTEC 6000 . Calculated in the HART module based on the current values read from COMTEC 6000
<b>3</b> Read Current & four variables	None	Byte 0-3 Current F Byte 4 PV unit code Byte 5-7 PV F Byte 9 SV unit code Byte 10-13 SV F Byte 14 TV unit code Byte 15-18 TV F Byte 19 QV unit code Byte 20-23 QV F		EEPROM	03 00  01 02	Calculated in the T004 module Unit 57 = % Oxygen 36 = mV Cell voltage 32 = DegC Cell Temperature 139 = ppm CO
<b>6</b> Write polling address	Byte 0 short address	As in command				Address 0 when used in 4-20 mA mode  A different address sets the device into multidrop mode
<b>11</b> Read Uniq id assoc with tag	Byte0-5 TAG	As in command				Max 8 characters
<b>12</b> Read message	Byte 0-23 message			EEPROM		
<b>13</b> Read tag descriptor, date	None	Byte 0-5 Tag A Byte 6-17 descriptor A Byte 18-20 date D		EEPROM EEPROM EEPROM		OXITEC OXITEC MODULE Use Delivery Date (All Default)
<b>14</b> Read PV sensor information	None	Byte 0-2 Sensor ser. Num. Byte 3 Unit for sen. lim Byte 4-7 Upper sen. Lim F Byte 8-11 Lower sen. Lim. F Byte 12-15 Min. span F		EEPROM		set by command 49 Unit code is (57 = %) fixed. The upper limits is fixed to 99.99%. The lower limit is fixed to 0.0001% . The minimum span is fixed to 0.01%
<b>15</b> Read PV output information	None	Byte 0 alarm select code Byte 1 transfer code Byte 2 Range unit code Byte 3-6 Upper range F Byte 7-10 Lower range F Byte 11-14 Damping val. F Byte 15 Write protect code Byte 16 Private-label distributor code				250 = Not Used 0 = Always linear PV unit code = % Read from COMTEC6000 code 16 Read from COMTEC6000 code 17 Read from COMTEC6000 code 18 0 No write protect mode is supported. 255 No distributor code



Command Number and Function	Data in Command	Data in reply	Response code	Storage type	Code	Comment
<b>16</b> Read final assembly number	None	Byte 0-2 final assembly number				
<b>17</b> Write message	Byte 0-23 message A	As in command		EEPROM		
<b>18</b> Write tag, descriptor and date	Byte 0-5 TAG A Byte 6-17 Descriptor. A Byte 18-20 Date D	As in command		EEPROM		
<b>19</b> Write final assembly number	Byte0-5 TAG	As in command	5 Too few bytes received 16 Access restricted	EEPROM		Max 8 characters

- A ASCII string (packed 4 characters per 3 bytes) – valid ASCII codes 32-96
- D Date(day,month,year –1990)
- F Floating point (4 bytes IEEE 754)



#### 4. COMMON PRACTICE COMMANDS

A limited set of commands is proposed implemented. These commands can be used by a minimum functionality Hand Held terminal like HH273 or PC software like AMS.

Command Number and Function	Data in Command	Data in reply	Response Code	Comments
<b>33</b> Read Device variables	Byte 0-dev Var code Byte 1-Dev Var code Byte 2-Dev Var code Byte 3-Dev Var code	Byte 0 dev Var code Byte 1 Unit code Byte 2-5 Device Var Value Byte 6 dev Var code Byte 7 Unit code Byte 8-11 Device Var Value Byte 12 dev Var code Byte 13 Unit code Byte 14-17 Device Var Value Byte 18 dev Var code Byte 19 Unit code Byte 20-53 Device Var Value	2 Invalid selection (invalid var code) 5 Too few data-bytes received	Devic var codes 0 =oxygen, 1= cell voltage, 2= cel temperatur, 3= co, 4= co sensor resistance, 5= co sensor temperature, 6=Heater Resistance  Code = 18
<b>34</b> Write damping value	Byte 0-3 damping value F	As in command	3 Passed parameter too large 4 Passed parameter too small 5 Too few data-bytes received 6 Transmitter specific error (CRC error)	Time for reaching 63% of step –low pass filter function see above. The filter calculation takes place in COMTEC 6000. The parameter is sent transparently through T004. Unit is sec. Limits are: lower limit 0sec. Upper limit 55sec. Code = 18
<b>35</b> Write Range values	Byte 0 Range unit code byte 1-4 upper range F byte 5-8 lower range F	As in command	2 Invalid selection (invalid unit code) 5 Too few data bytes received 10 Lower range value too low 11 Upper range value too high 12 Upper range value too low 6 Transmitter specific error (CRC error)	The range values are written directly into COMTEC 6000. Unit code always % We have one problem with the measure range: -OXITEC has two adjustable measure ranges, this ranges can be switched manually or by remote. -The second range must be smaller than the first, so the limits are defined on the actual range setting of the first one:  Example if the first range is 5% to 20% the limits for the second range are 5% and 20 % (it is a range within a range) Lower Range code 16 Upper Range code 17
<b>42</b> Perform master reset	none	none	16 Access restricted	Restore T004 parameters to default values.

Command Number and Function	Data in Command	Data in reply	Response code	Comments
48 Read additional transmitter status	None	Byte 0-3 Status byte 4-5 Calibration status Byte 6 Com status byte7 Co status byte 8 Co calib status		Status signals from COMTEC Codes for the status are 04 & 05
49 Write PV sensor serial number	Byte 0-2 sensor serial number	As in command	5 Too few data-bytes received	This command is assume used by Enotec to set the sensor serial number in the factory. The result is displayed in command 14  EEPROM data
59 Write number of preambles	Byte 0 # of response preamble bytes	as in command	3 Passed parameter too large 4 Passed parameter too small 5 Too few data-bytes received	Default 5 Legal range 3-20 preambles. EEPROM data
108 Write burst mode command number	Byte 0 Burst mode command number	As in command	2 Invalid selection 5 Too few data-bytes received	Command 1,2 and 3 possible choices EEPROM data
109 Burst mode control	Byte 0 Control: 0 = exit 1 = enter	As in command	2 Invalid selection 5 Too few data-bytes received	Depends on selected command number EEPROM data



## 5. DEVICE SPECIFIC COMMANDS

For general application of the Device Specific commands a Device Description is required. The “Generic HART transmitter” applications in Hand held communicator HH273 or PC configuration program like AMS from Fisher Rosemount, there will be no support for the following commands. These commands are primarily intended for factory use with a proprietary toll for device set-up. The Device Description will also describe the menu structure. Commands that affect the modes and states of the device can be included in the menu structure. For each command the response code is defined. In the case that there are no errors in the request, the device will return response code 0 “No errors”.

Command Number and Function	Data in Command	Data in reply	Response code	Comments
165 Read EEPROM float	byte 0-1 Address Data	Byte 0 – 3 Data F	2 Invalid selection ( address-range) 5 Too few data-bytes received	Address is entered in hex format
166 Write EEPROM float	Byte 0-1 Address Data byte 2-5 float value	As in command	2 Invalid selection ( address-range) 5 Too few data-bytes received	Address is entered in hex format
167 Read EEPROM byte	byte 0-1 Address Data	Byte 0 Data B	2 Invalid selection ( address-range) 5 Too few data-bytes received	Address is entered in hex format
168 Write EEPROM byte	Byte 0-1 Address Data Byte 2 byte	As in command	2 Invalid selection (refers to address-range) 5 Too few data-bytes received	Address is entered in hex format
175 Erase EEPROM	None	None		Purely test and development. If this cmd is issued, during restart the device comes up with default set up.
200 Read F type data	Byte 0 Code	Byte 0 Code Byte 1 Dimension Byte 2-5 Data F	2 Invalid selection 5 Too few data-bytes received 6 Transmitter specific error (CRC error)	Valid codes are (7, 8, 9, 10, 11, 12, 14, 16, 17, 22, 23, 24 & 25) Dimension HART coding Data type float
201 Write F type data	Byte 0 Code byte 1 Dimension byte 2-5 Data F	As in command	2 Invalid selection 5 Too few data-bytes received 6 Transmitter specific error (CRC error)	Valid codes are (7, 8, 9, 10, 11, 12, 14, 16, 17, 22, 23, 24 & 25) Dimension HART coding Data type float
202 Read N type data	Byte 0 Code	Byte 0 Code Byte 1 Dimension Byte 2-5 Data L	2 Invalid selection 5 Too few data-bytes received 6 Transmitter specific error (CRC error)	Valid codes are ( 4, 3, 15, & 18) Dimension HART coding Data 32 bit unsigned 32
203 Write N type data	Byte 0 Code Byte 1 Dimension Byte 2-5 Data L	As in command	2 Invalid selection 5 Too few data-bytes received 6 Transmitter specific error (CRC error)	Valid codes are ( 4, 3, 15, & 18) Dimension HART coding Data 32 bit unsigned 32
204 Read U type data	Byte 0 Code	Byte 0 Code Byte 1 Dimension Byte 2-3 Data short	2 Invalid selection 5 Too few data-bytes received 6 Transmitter specific error (CRC error)	Valid codes are (3, 26, & 27) Dimension HART coding

Command Number and Function	Data in Command	Data in reply	Response code	Comments
208 Issue Execute function	Byte 0 Code	As in command	2 Invalid selection 5 Too few data-bytes received 6 Transmitter specific error (CRC error)	Valid codes are 20, 21, 28 & 29..
253 Read T004 Module Data	Byte 0 Index	Byte 0 Index Byte 1- 13 Module data	2 Invalid selection (0 & 1 valid indices) 5 Too few databytes received	0 Module Document data T004_03_30 1 Print Card data

## 6. T004 DATAFLOW

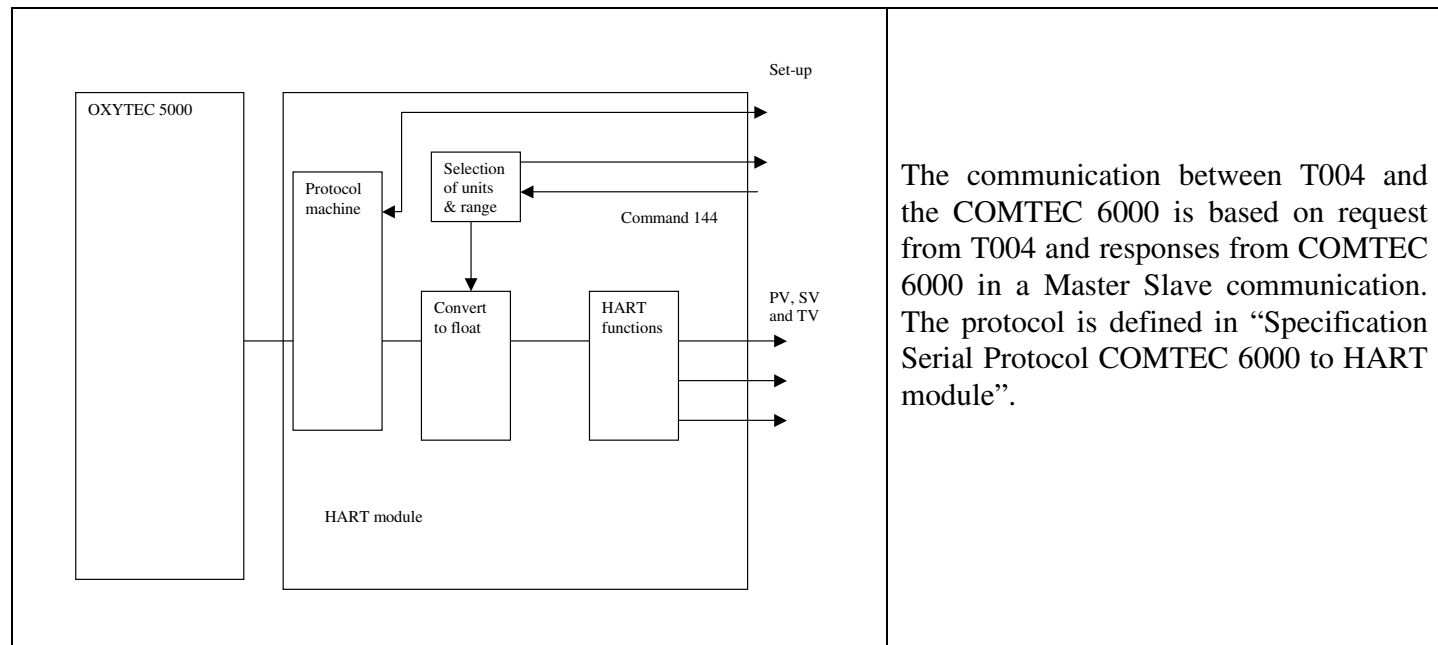

The communication between T004 and the COMTEC 6000 is based on request from T004 and responses from COMTEC 6000 in a Master Slave communication. The protocol is defined in “Specification Serial Protocol COMTEC 6000 to HART module”.

### Dynamic variables.

The T004 is continuously reading the dynamic variables from OXITEC using the serial communication line. Each 5 sec. it reads all the variables and updates PV, SV and TV. The loop-current is also read each 5 sec. The variable “% of Range”, that is read using command 2, is calculated in T004 as a percentage of the loop range 4-20mA. The range values are read from COMTEC 6000. The calibration status and the status is read each 10 sec.

#### ARRAY OF COLLECTION transmitter\_variables

```
{
    HELP [transmitter_variable_help];
    ELEMENTS
    {
        0, Oxigen           "Gas Level", "Dynamic variable.";
        1, Cellvoltage,     "Cell volt", "Dynamic variable";
        2, Celltemp,       "Cell temp", "Dynamic variable ";
        3, CO,             "CO", "Dynamic variable.";
        4, COsensor resistance,"Resistance", "Dynamic variable.";
        5, COsensor temp,  "Sensor Temp""Dynamic variable.";
        6, Heater Resistance, "Heater Res", "Dynamic variable.";
    }
}
```

The dynamic variable selection is fixed in the device. The transmitter variables from 0 to 3 are PV to QV in the same order. All dynamic variables are accessible using command 33.

In case of a communication error between the OXITEC and T004, a reading may be lost. This simply implies that the measured variable is not updated. The HART status “Update failure” is used in this case. If there is a permanent loss of communication defined as no update for 50 sec (10 readings from OXITEC), This is flagged in the HART status response from the device as “Device failure”.

### Read Status

When the user wants to read status, he sends the HART command 48 “Read additional status”. The reading from this register is maximum 10 sec. old. Each 5 sec. the T004 sends a command reading either code 04 or 05. The status flags can also be read using generic command. We distinguished between alarms and errors. We have two adjustable limits if this limits are exceeded an alarm is set. An error is set only by a system fault. We probably need to know the coding of the Status bits the two status bytes from OXITEC to distinguish between errors and alarms.

If any bit in the COMTEC 6000 Status signals (Code 04) is changed, the HART status flag “Read additional status” is set. This may force a HART Master to read command 48 in order to read the status of the instrument. The HART flag will be reset when the status is read. This will allow the Master to read the status as a consequence of any change of state in the COMTEC 6000.

Coding of Status :

Bit 0	"constant out of tolerance",	
Bit 1	"slope out of tolerance",	
Bit 2	"ref.gas flow to low",	
Bit 3	"cal.gas flow to low",	
Bit 4	"heating system don't work",	
Bit 5	"wire breakage thermoelement",	
Bit 6	"error cell signal out of range",	
Bit 7	"error probe heater",	
Bit 8	"temp. of electronic out of spec.",	
Bit 9	"probe temperature to high",	
Bit 10	"probe temperature to low",	
Bit 11	"alarm limit1",	
Bit 12	"alarm limit2",	
Bit 13	"data fault EEPROM",	
Bit 14	"measuring value memory active",	
Bit 15	"error by trying ACAL",	also occurs if any error by calibration over HART
Bit 31	"Calibration Busy"	

Coding of Com status

Bit 0 "Permanent internal communication failure"

The HART module has lost communication with OXITEC/COMTEC

The COMTEC has two additional status bytes

Byte 7 of the additional status is copied from the third byte of the OXITEC/COMTEC status and is coded as follows

```
VARIABLE error_code_5
{
    LABEL "CO status ";
    HELP "Errorstatus of COMTEC 6000";
    CLASS DEVICE;
    HANDLING READ;
    TYPE BIT_ENUMERATED
    {
        {0x01, "Calib margin"},
        {0x02, "Wire break"},
        {0x04, "Heater"}
    }
}
```

Byte 6 is the calibration status for COMTEC and is read from COMMAND 27

### Calibrate

The Calibration is started by issuing an “HART execute command” command 208. The HART command requires an immediate response and cannot wait for the calibration to complete. A positive HART response will be given if the COMTEC 6000 accepts the command. This is a verification that the calibration has started. In order to see if the calibration is successful or not, the Master must read command 48 “Read additional Status” in order to read the calibration status. This procedure will be used both for single point and two-point calibration.

### Power-up

The device determines whether it is an OXITEC or a COMTEC device at power-up. This is done by reading the Command 26. If the instrument returns a logic “1”, the instrument is a COMTEC 6000 instrument and the Device ID is set to “0xEE”. Otherwise it is a OXITEC instrument and the Device ID is 0xEC”. Until the T004 has determined whether it is an OXITEC or a COMTEC device it will not respond on HART.

The number of parameters that the instrument shall respond to depends on whether it is an OXITEC or a COMTEC.

In the case the device is a COMTEC device, two additional status bytes are added to the “Additional Status” response.

The COMTEC system has a power up time. This time depends on the installation of the probe of the type of probe and the environment. The COMTEC will set a status flag for heating up (power up) phase. This is flagged in bit 30 of the Status. The Cold start flag is set in the power-up time and will be turned off when the instrument is ready.

### Multidrop

Multidrop mode allows several HART transmitters to be connected together in a network. The loop current is normally forced to 4 mA in this case.

The T004 can be set into multidrop mode. This is done by giving the device a short address different from 0, using command 6. It is taken out of multidrop again by setting the address to 0. There is no link between COMTEC and T004 that allow the loop current to be forced to 4 mA. It is, however, possible to wire a pure HART connection to the COMTEC allowing HART multidrop mode.

## Communication

The T004 protocol machine controls the communicating with the COMTEC 6000. This protocol machine has the following functions:

- Generation of COMTEC 6000 frames
- Observing COMTEC 6000 time-out
- Conversion of data (i.e.)
  - ASCII – float
  - ASCII – Unsigned 32
- Conversion of dimension into Unit code
  - Table with the required unit codes
- Conversion of code
  - ASCII - unsigned 8
- Arbitration of traffic.

The time-out time on the communication is 180 ms in order to allow a transparent link on HART.

The data elements in the OXITEC data frame are converted in the protocol machine. This is done to make the data types HART compatible. On HART the following data types are used, IEEE float, HART unit codes etc.

### Arbitration of traffic.

Reading of dynamic variables is done on a fixed schedule, once every 5 sec. A request for a set-up parameter or an execute command may appear at any time and is executed immediately if no traffic with the OXITEC is pending. If scheduled traffic is about to start, the scheduled traffic (reading of dynamic variables) will wait. If scheduled traffic is in progress, when the external read or write request takes place, the T004 will return a “busy” status. The Master will in this case have to reissue the request.

### Master reset

This command acts on the HART module only.

### Device Malfunction.

This flag is set when T004 is a fault state and if there is an error in OXITEC.

## 7. STATUS FLAGS

Each HART response conveys the HART application status. Below is usage of these status bits shown:

Flag name	Usage
Device malfunction	No communication with COMTEC 6000 or error in OXITEC
Configuration changed	Not used
Cold start	During power-up of the instrument.
Additional status	OXITEC Status signals set
Output current fixed	Not used
Analog output saturated	Set in case current range is exceeded
Variable (not PV) is out of limits	Not used
Primary value out of limits	Set in the case measured value outside sensor limits

## 8. MECHANICAL

The board layout is shown below. T004 will receive 5 V and Gnd from COMTEC 6000. The T004 loop connection is made to the two lines on the 4-20mA output.

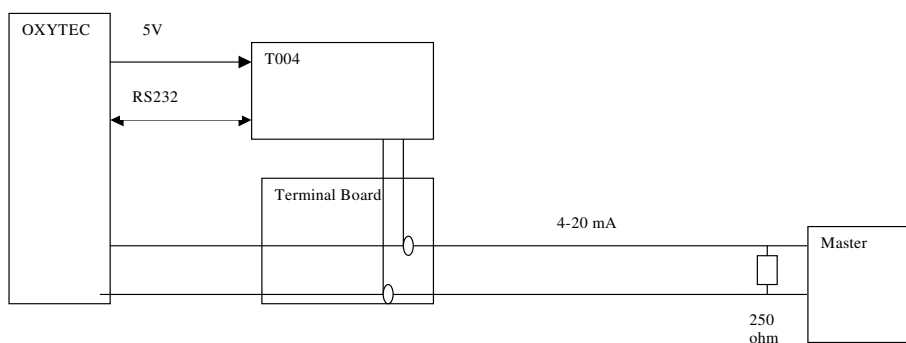

The figure above shows the Wiring connection between COMTEC 6000 and T004

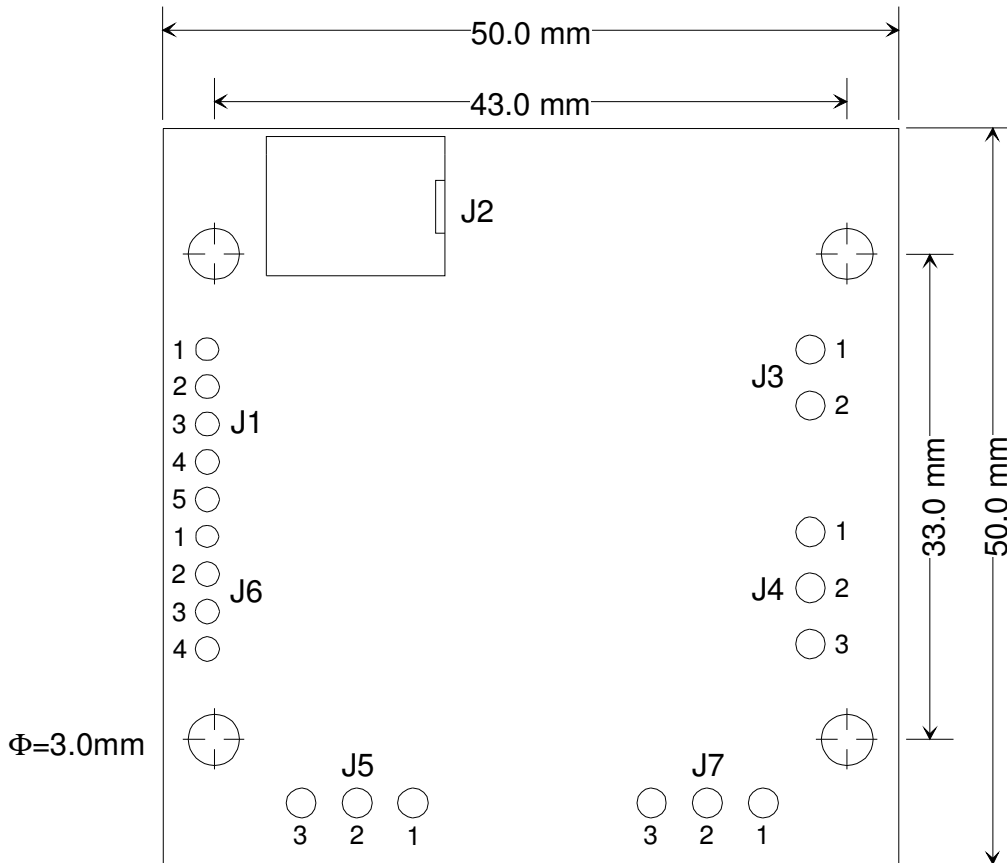

**ELECTRICAL CONNECTIONS (SOLDERING HOLES)**

Connection	Pin No.	Signal Type	Description
HART+	3	Line connection	Connection for the 4-20 mA and HART line
HART-	2	Line connection	Connection for the 4-20 mA and HART line
EMC GND	1		Termination of shield - optional

**Table 1** Current loop T004 connections – J4

The loop connection may optionally be supplied by a screw terminal. The input is polarity sensitive.

Connection	Pin No.	Signal Type	Description
VCC	1	Power Input	Not used
GND	2	Power	Not used

**Table 2** Power connection – J3 –

The power connection may optionally be supplied by a screw terminal

Connection	Pin No.	Signal Type	Description
	1		NC
GND	2		Power ground connection to COMTEC 6000
SO	3	Digital Output	NC
SI	4	Digital Input	NC
SCK	5	Digital Output	NC

**Table 3** Sensor interface connection – J1 – digital

Connection	Pin No.	Signal Type	Description
IO0	1		NC
IO1	2		NC
IO2	3		NC
VCC	4		Power – 5 Vdc supplied by COMTEC 6000

**Table 4** Sensor interface connection – J6 - digital

The configuration must be specified when ordering

Connection	Pin No.	Signal Type	Description
Tx/Data_A	1	RS232	Transmit from T004
Rx/Data_B	2	RS232	Receive to T004
GND	3		Signal ground

**Table 5 Sensor interface connection – J5 – RS232 or RS485 interface**

The module can be configured either for HART output or a MODbus/RS485 output. The configuration is chosen by onboard 0 ohm resistor straps.

Connection	Pin No.	Signal Type	Description
MOD_A	1	RS485	NC
MOD_B	2	RS485	NC
EMC Gnd	3	Protection	NC

**Table 6 Sensor interface connection – J7 – External MODbus interface (RS485)**